

Current Sensor

Product Series: STK-616KF

Part number: STK-616KF-40AC
STK-616KF-65AC

Version: Ver 1.2.3

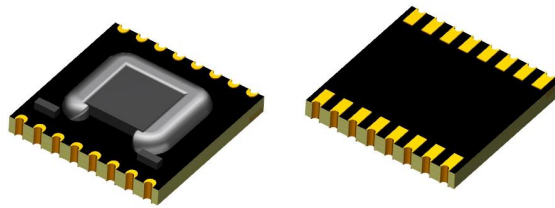

CONTENT

1.	Description.....	2
2.	Part number definition.....	3
3.	Temperature vs Current.....	3
4.	Electrical data STK-616KF-xxAC.....	4
5.	Dimension & Pin definitions.....	5
6.	Pin definitions.....	6
9.	Delay time.....	7
10.	Typical Application of STK-616KF.....	8
11.	Examples of OCD function.....	9
12.	General information on OCD.....	10
13.	PACKAGE MATERIALS INFORMATION.....	12

1. Description

The STK-616KF series current sensor is based on TMR (tunnel magnetoresistance) technology and open-loop design. It is suitable for DC, AC pulsed and any kind of irregular current measurement under the isolated conditions.

Typical applications

- AC Variable speed drives
- Inverter
- Electric welder power supply
- Switched model power supplies (SMPS)

General parameter

Parameter	Symbol	Unit	Value
Working temperature	T_A	°C	-40 ~ 125
Storage temperature	T_stg	°C	-40 ~ 125
Mass	m	g	0.5

Absolute maximum rating

Parameter	Symbol	Unit	Value
Supply voltage	V _{cc}	V	6
ESD rating (HBM)	U_ESD	kV	4
Junction temperature	T_J	°C	150

Remark: the unrecoverable damage may occur when the product works on the conditions over the absolute maximum ratings. Long-time working on the absolute maximum ratings may cause the degradation on performance and reliability.

Isolation parameter

Parameter	Symbol	Unit	Value	Comment
RMS voltage for AC test 50Hz/1 min	U _d	kV	2	
Impulse withstand voltage 1.2/50μs	Ū _w	kV	10	
Clearance distance (pri. -sec)	d _{Cl}	mm	7	Determined by customer's layout
Creepage distance (pri. -sec)	d _{Cp}	mm	7	

Measuring current table

Product	Optimized Range I _{pn} (A)	Sensitivity, (mV/A)	V _{cc} (V)	T(°C)
STK-616KF-40AC-1-1.65-E-2-C	±40A	33	3.3V	-40 ~ 125
STK-616KF-65AC-1-1.65-E-2-C	±65A	20	3.3V	-40 ~ 125
STK-616KF-40AC-1-1.65-E-2-Z	±40A	33	3.3V	-40 ~ 125
STK-616KF-65AC-1-1.65-E-1-Z	±65A	20	3.3V	-40 ~ 125

2. Part number definition

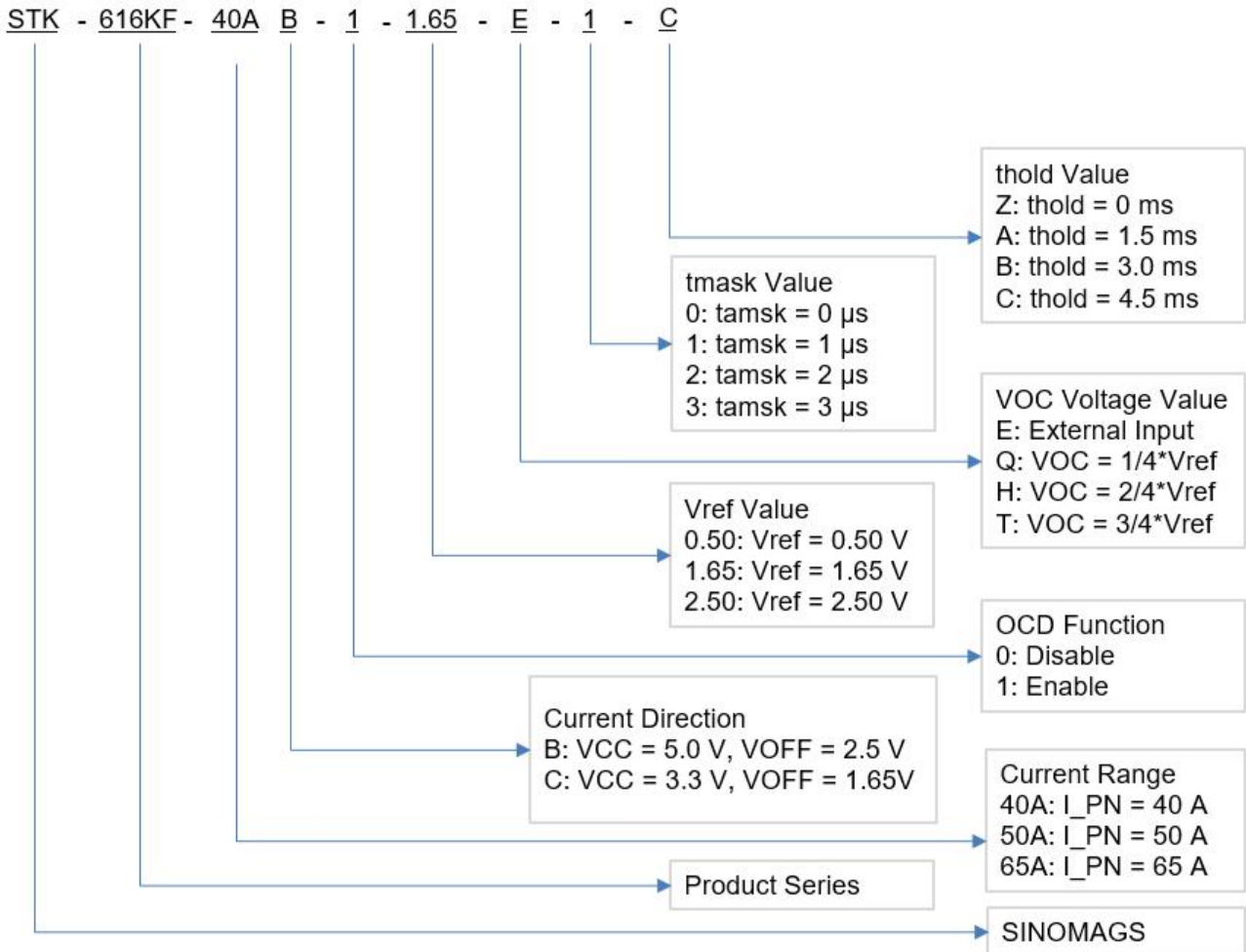

3. Temperature vs Current

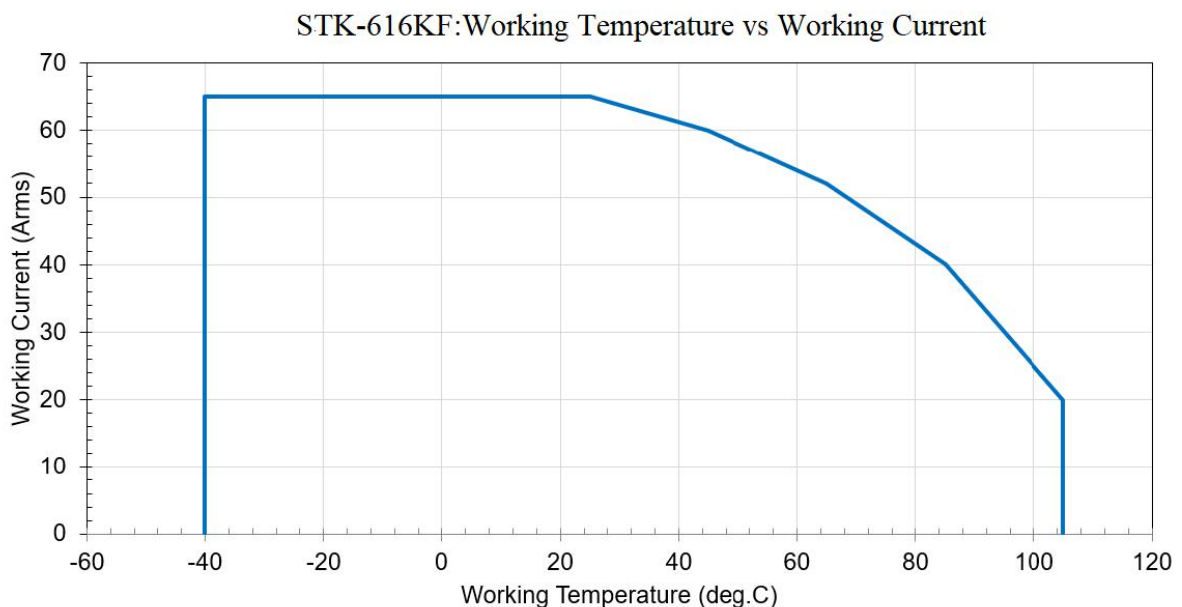

4. Electrical data STK-616KF-xxAC

 Condition: $T_A = 25^{\circ}\text{C}$, $V_{CC} = 3.3\text{ V}$

Parameter	Symbol	Unit	Min	Typ	Max	Comment
General parameters						
Primary nominal current	I _{pn}	A	-40		40	STK-616KF-40AC
			-65		65	STK-616KF-65AC
Supply voltage	V _{cc}	V	3.15	3.3	3.45	
Current consumption	I _{cc}	mA		7	12	
Quiescent voltage	V _{off}	V	1.6	1.65	1.7	
Internal output resistance	R _{out}	Ω	1		30	
Theoretical gain	G _{th}	mV/A		33		STK-616K-40AC
				20		STK-616K-65AC
OCD function (if applicable)						
OCD range	VOC	V	0.3		1.6	
FOULT error		%		5%		% of OCD
OCD Hysteresis	I _{HYS}	%		10%		% of OCD
OCD Fault Mask	t _{mask}	μs		1		0, 1, 2, 3 μs
OCD Fault Mask error	T _{mask_error}	ns		125		
OCD Fault Hold Time	t _{hold}	ms		4.5		0, 1.5, 3, 4.5 ms
Rated linearity error@25°C	Non-L	%I _{pn}		±1.5		±I _{pn}
Accuracy performance						
Delay time	t _{delay}	μs		0.2		@400 kHz
Step response time	t _{res}	μs		0.5		@90% of I _{pn}
Frequency bandwidth	BW	kHz		1000		@-3dB
Output voltage noise	V _{noise}	mVpp		20		100 ~ 120 kHz @250 kHz S.R.
Accuracy @ 25°C	X	% I _{pn}		±1.5		@ 0.5*I _{pn}
Thermal drift of G _{th}	Gain _T	% of G _{th}	-1.5		1.5	@ -40~105°C
Thermal drift of V _{off}	V _{off_T}	mV	-15		15	drift related to the value @25°C
Total Accuracy	X _{TRange}	% of I _{pn}	-3		3	

5. Dimension & Pin definitions

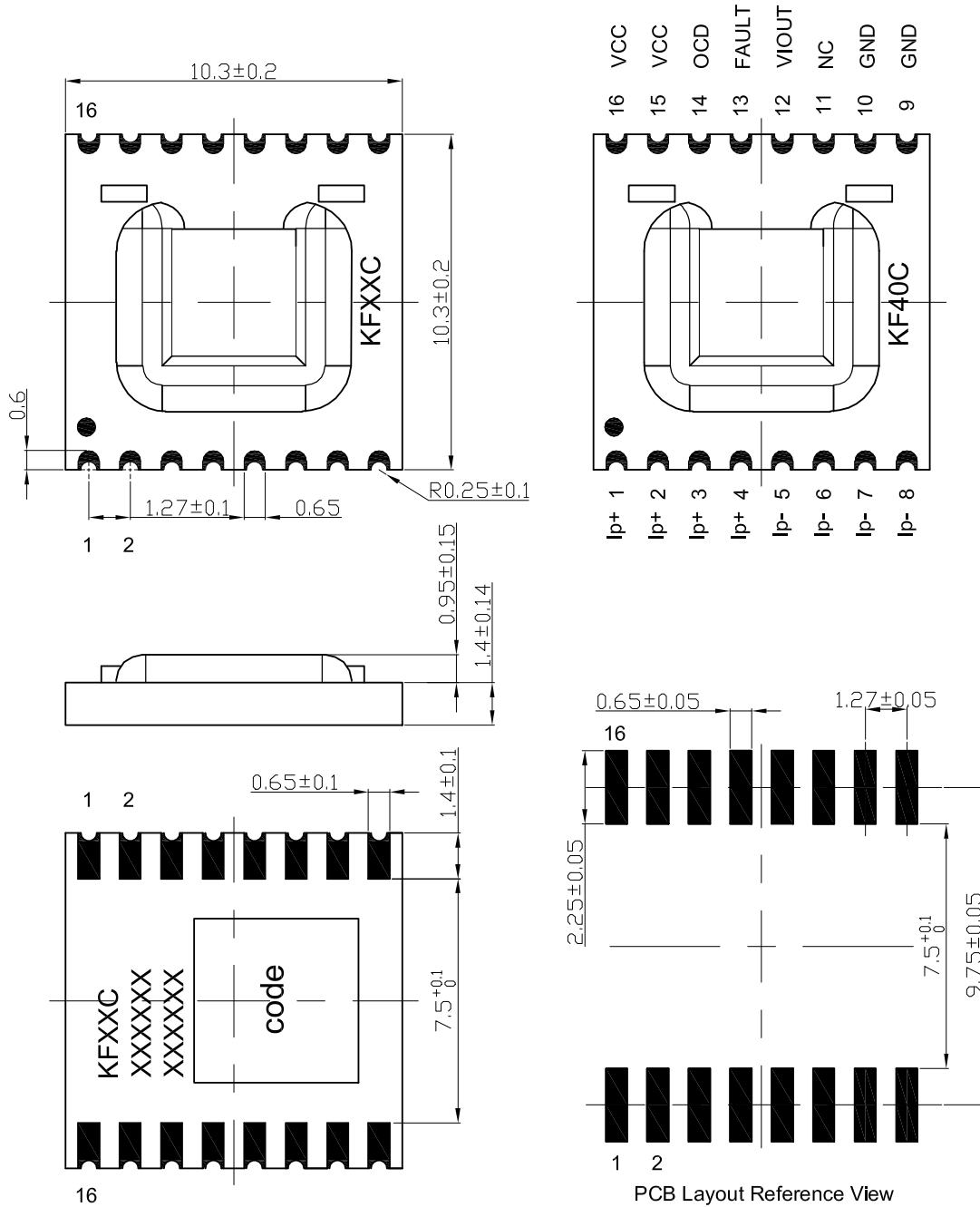

The mark of "KFXXC" on the top surface shows the information on the "Part number": "KF" = "STK-616KF", "XX" = "Product sensing range", "C" = "Current direction".

6. Pin definitions

PIN	Symbol	Description
1,2,3,4	IP+	Primary conductor pin (+)
5,6,7,8	IP-	Primary conductor pin (-)
9,10	GND	Ground pin (GND)
11	NC	Internal use only
12	VIOUT	Sensor output pin
13	FAULT	Over current detection alarm output, the pin is open leakage output. Normally, the output of fault pin is high level
14	OCD	Over current detection threshold input pin
15,16	VCC	Power supply pin

7. PCB layout recommendation

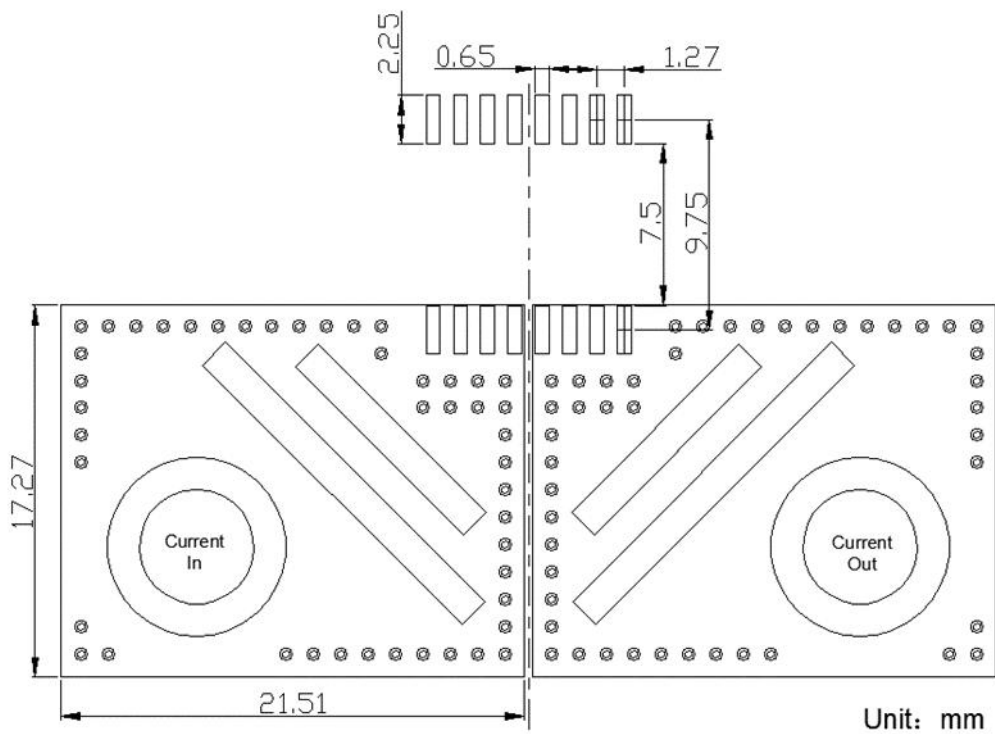

8. Frequency band width

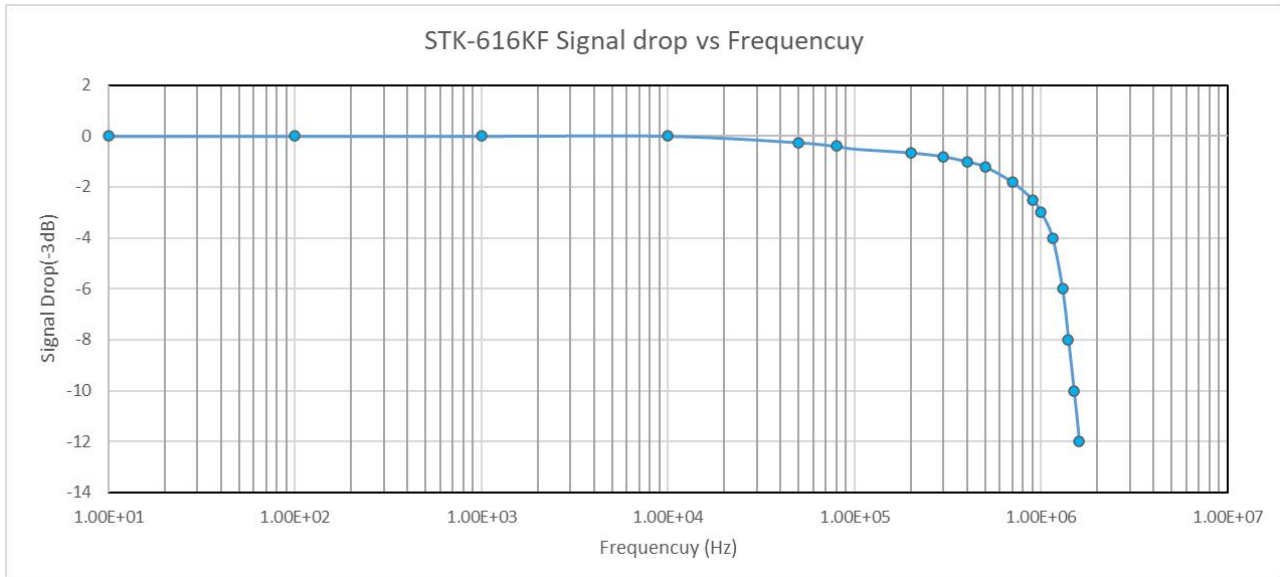

9. Delay time



The typical delay time of STK-616KF current sensor. The delay of output to the primary triangle current with a frequency of 400 kHz is around 130 ns.

10. Typical Application of STK-616KF

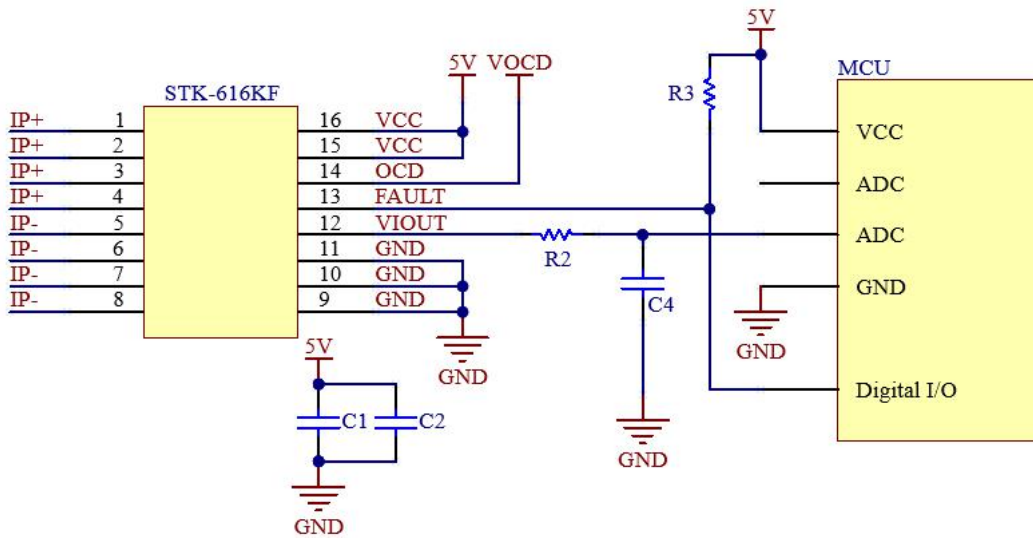

Remark:

With below recommended setting, the response speed of the chip will be not affected:

$R3 = 5\text{ k}\Omega$, $C1 = 1\text{ }\mu\text{f}$, $C2 = 10\text{ nF}$, $C4 = 50\text{ pF}$.

While, $R2$ and $C4$ constitute RC filter circuit. The relationship between RC value and frequency is shown in below Table

R2 (kohm)	C4 (nF)	Theoretical band width $f = 1/(2\pi RC)$ (kHz)	Measured band width (kHz)
1	1	150	~ 150
0.4	1	400	~ 400
0.16	1	1000	~ 1000

11.Examples of OCD function

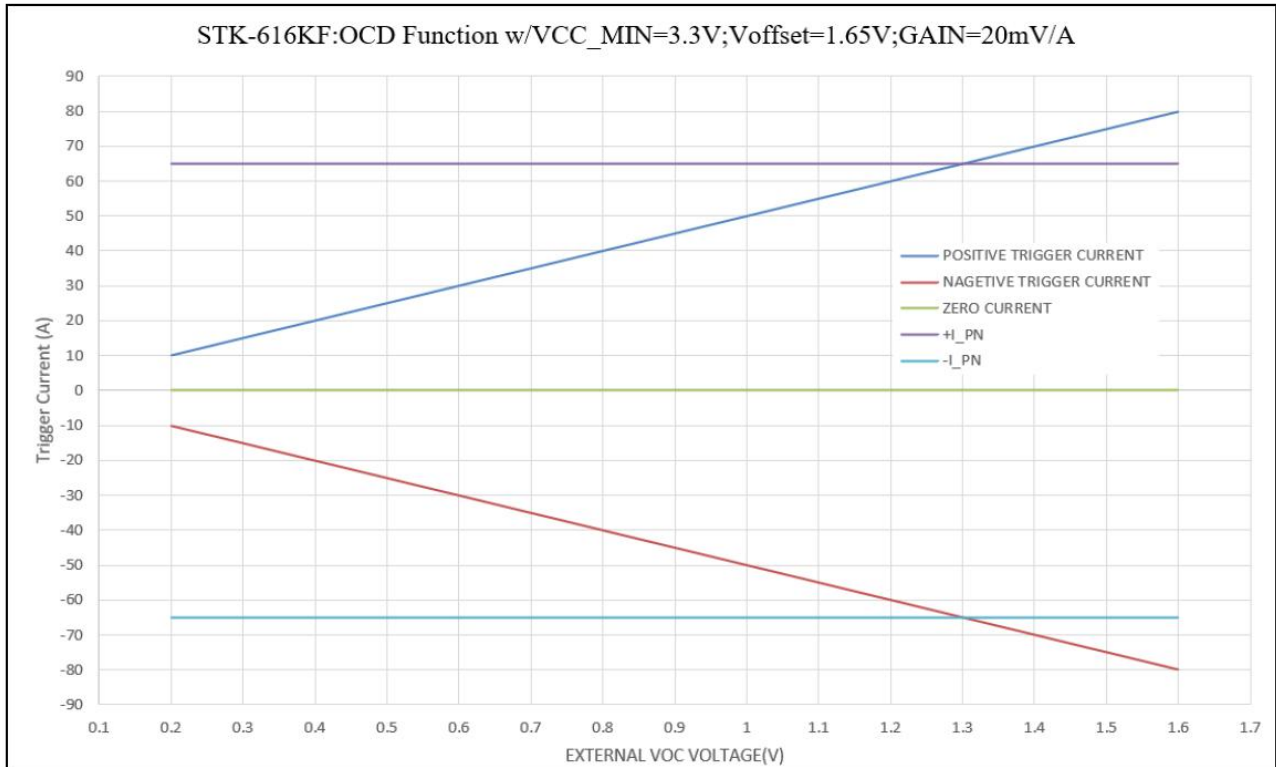

OCD function for STK-616KF-65AC

12. General information on OCD

This section describes the general information on OCD function, the specific functions, which are not listed in the section of “electrical data”, can be defined per request.

Since the trigger voltage is set after the second amplifier, the OCD function supports that the trigger current can be higher than I_{pn} . The trigger voltage can be defined:

- a) $V_{ref} = 2.5\text{ V}$
 - a) $0.5\text{ V} \cong VOC \cong V_{cc} - 1.7\text{ V};$
 - b) Trigger voltage = $V_{ref} \pm VOC;$
 - c) Trigger current = $(V_{ref} \pm VOC - V_{off}) / G_{th};$
- b) $V_{ref} = 1.65\text{ V}$
 - a) $0.3\text{ V} \cong VOC \cong V_{cc} - 1.7\text{ V};$
 - b) Trigger voltage = $V_{ref} \pm VOC;$
 - c) Trigger current = $(V_{ref} \pm VOC - V_{off}) / G_{th};$
- c) $V_{ref} = 0.5\text{ V}$
 - a) $0.2\text{ V} \cong VOC \cong 0.5\text{ V};$
 - b) Trigger voltage = $V_{ref} + 8 \cdot VOC;$
 - c) Trigger current = $(V_{ref} + VOC - V_{off}) / G_{th};$

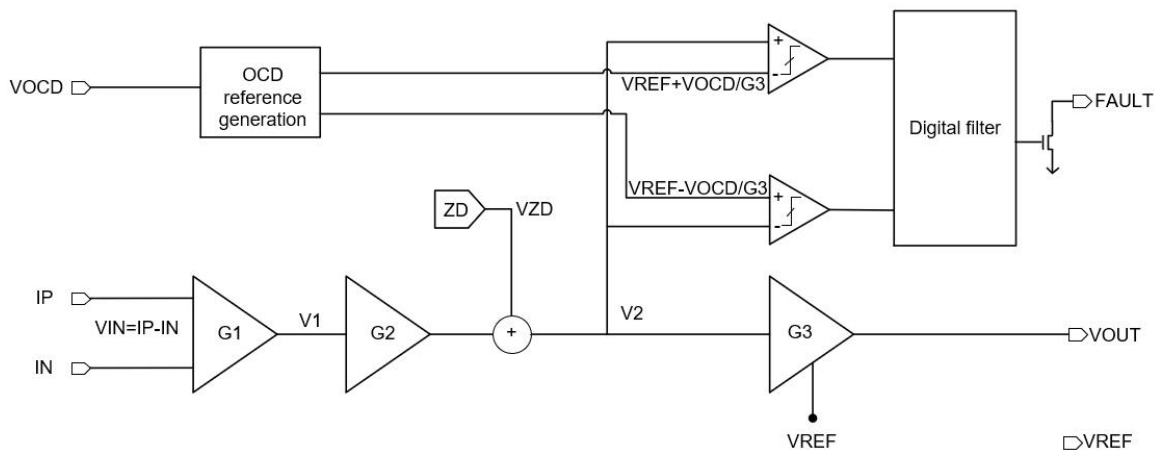

Functional Block Diagram on OCD function when $V_{ref} = 2.5\text{ V}$

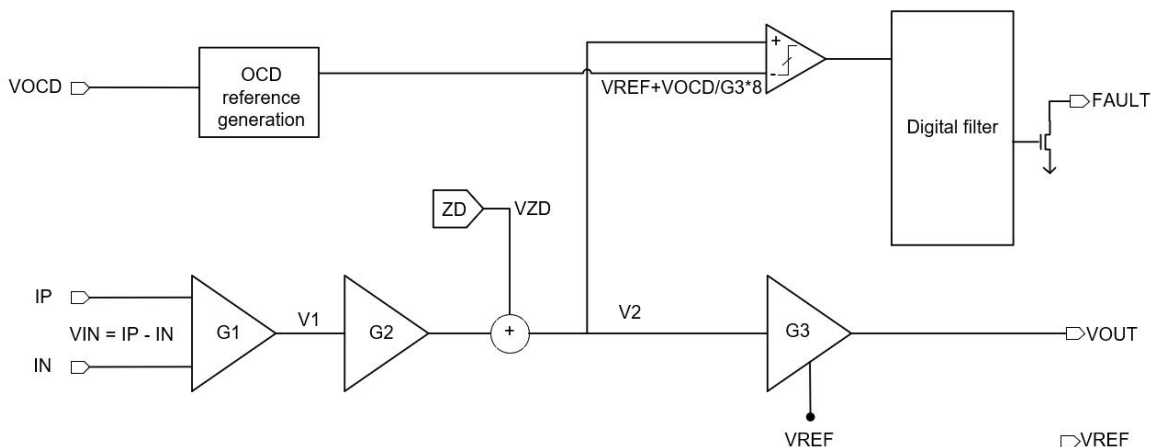

Functional Block Diagram on OCD function when $V_{ref} = 0.5\text{ V}$

With the above definition, below shows the relationship between trigger voltage and the setting of Vcc, VOC.

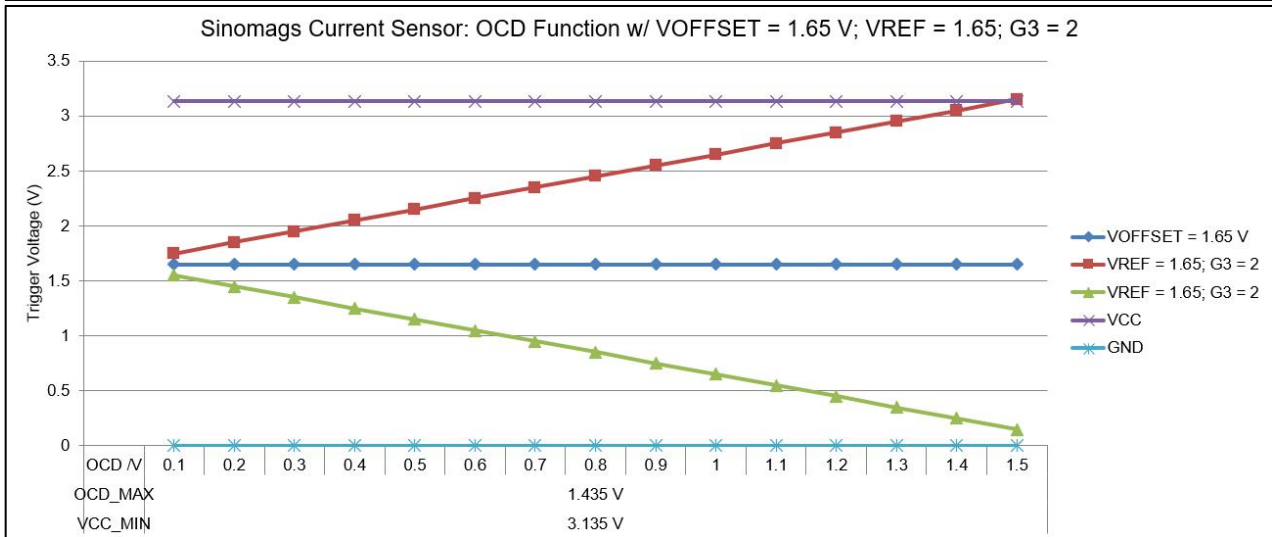
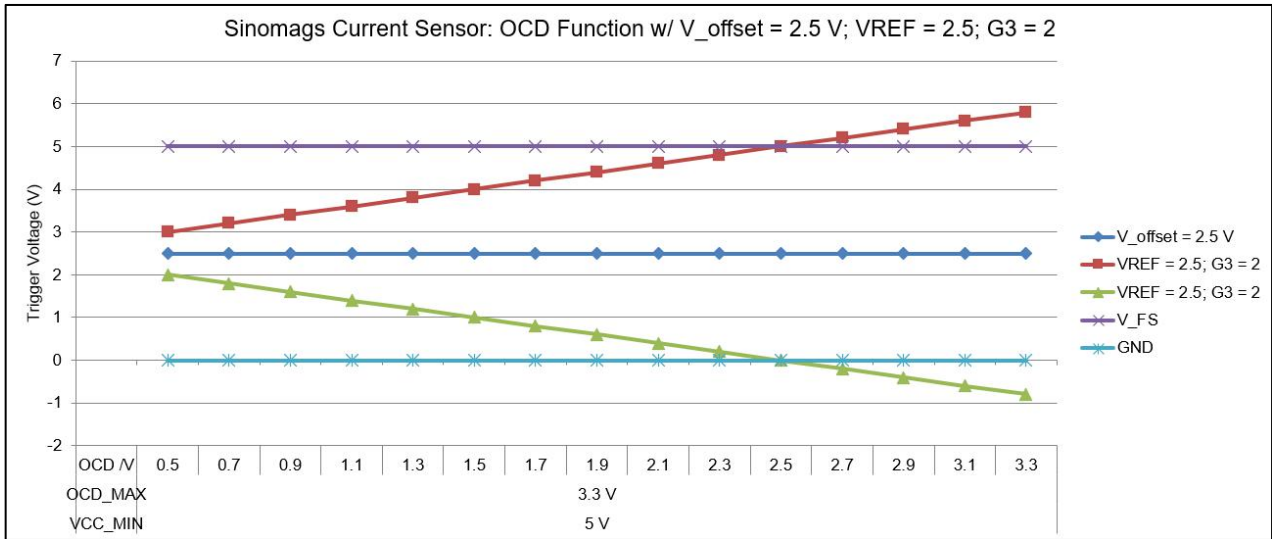

13. PACKAGE MATERIALS INFORMATION

TAPE AND REEL INFORMATION

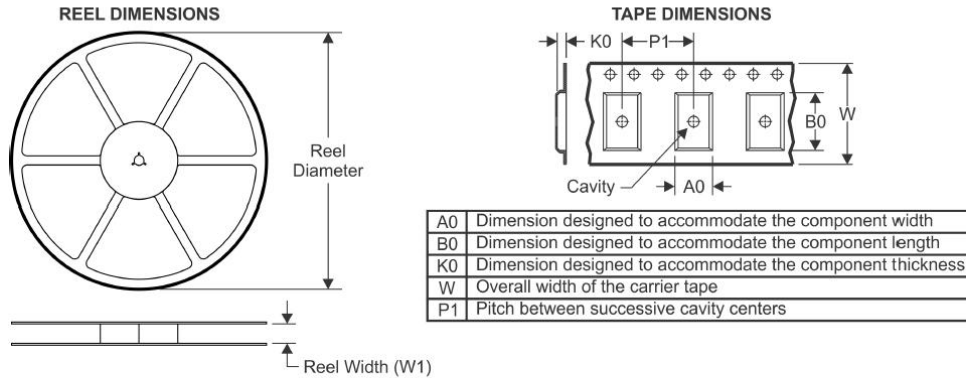

QUADRANT ASSIGNMENTS FOR PIN 1 ORIENTATION IN TAPE

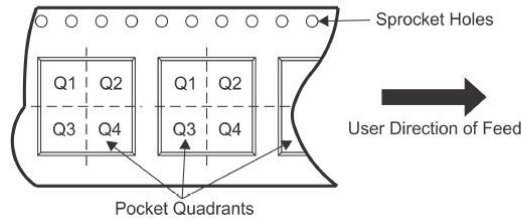

All dimensions are nominal

Device	Package Type	Package Drawing	Pins	SPQ	Reel	Reel	A0 (mm)	B0 (mm)	K0 (mm)	P1 (mm)	W (mm)	Pin1 Quadrant
					Diameter (mm)	With W1 (mm)						
STK-616KF	16-WDFN	WDFN	16	2000	330.0	24.0	12.0	12.0	3.5	16.0	24.5	Q1