

Current Sensor

Product Series: STK-600/M

STK-600/M-050AB5, STK-600/M-100AB5
STK-600/M-150AB5, STK-600/M-166AB5
STK-600/M-200AB5, STK-600/M-250AB5
STK-600/M-300AB5, STK-600/M-400AB5
STK-600/M-050AB3, STK-600/M-100AB3
STK-600/M-150AB3, STK-600/M-200AB3
Part number: STK-600/M-250AB3, STK-600/M-300AB5
STK-600/M-400AB3, STK-600/M-200AC3
STK-600/M-250AC3, STK-600/M-050AU5
STK-600/M-100AU5, STK-600/M-150AU5
STK-600/M-200AU5, STK-600/M-250AU5
STK-600/M-300AU5, STK-600/M-400AU5
STK-600/M-100AU3, STK-600/M-150AU3

Version: Ver 1.4

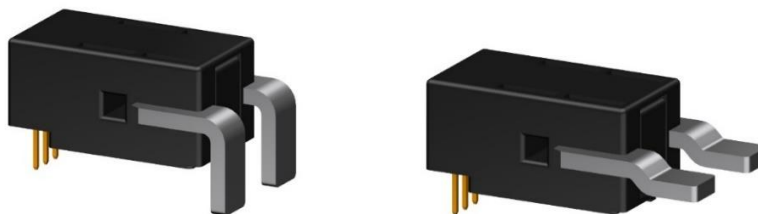

Sinomags Technology Co., Ltd

Web site: www.sinomags.com

CONTENT

1.	Introduction	2
2.	Package: 5-pin package	2
3.	Features and Benefits	3
4.	Product Information	3
5.	Electrical Data	4
6.	Response Time	9
7.	Frequency Bandwidth.....	9
8.	Dimension & Pin Definitions	10

1. Introduction

The STK-600/M series current sensor is based on TMR (tunnel magnetoresistance) technology, and it has an open-loop design. It is suitable for DC, AC pulsed and any kind of irregular current measurement under the isolated conditions.

Typical applications

- AC Variable speed drives
- Motor driver
- Electric welder power supply
- BMS

General parameter

Parameter	Symbol	Unit	Value
Working temperature	T_A	°C	-40 ~ 125
Storage temperature	T_stg	°C	-40 ~ 125
Mass	m	g	4

Absolute maximum rating

Parameter	Symbol	Unit	Value
Supply voltage (not-destructive)	V _{CC}	V	6
ESD rating (HBM)	U _{ESD}	kV	4

Remark: the unrecoverable damage may occur when the product works on the conditions over the absolute maximum ratings. Long-time working on the absolute maximum ratings may cause the degradation on performance and reliability.

Isolation parameter

Parameter	Symbol	Unit	Value	Comment
RMS voltage for AC test 50Hz/1 min	U _d	kV	4	
Clearance distance (pri. -sec)	d _{Cl}	mm	8	Shortest distance through air
Creepage distance (pri. -sec)	d _{Cp}	mm	8	Shortest path along device body
Case material			V0 according to UL 94	

2. Package: 5-pin package

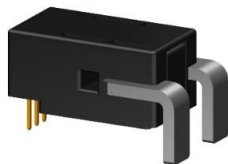

PFF Leadform

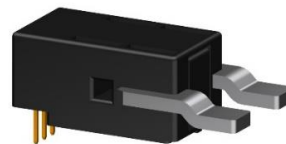

PSF Leadform

3. Features and Benefits

UL certified, File No. E507664.

4. Product Information

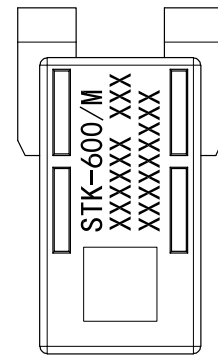
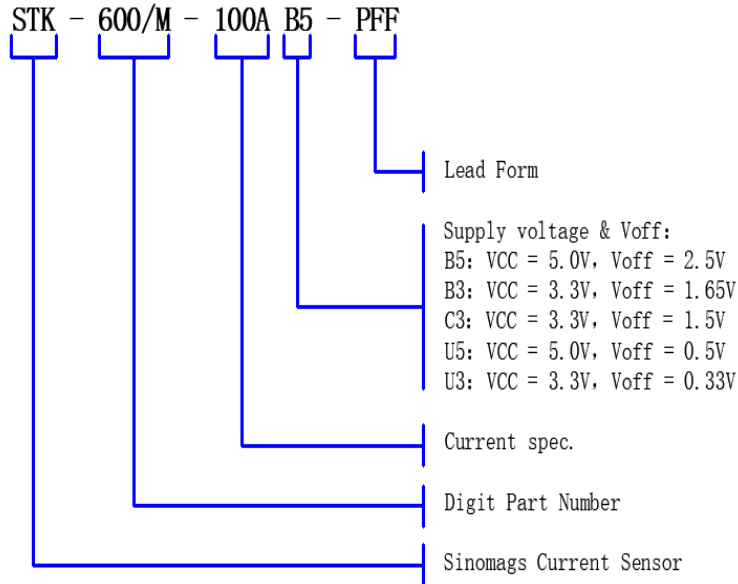

Production information is printed on the package surface by laser marking.

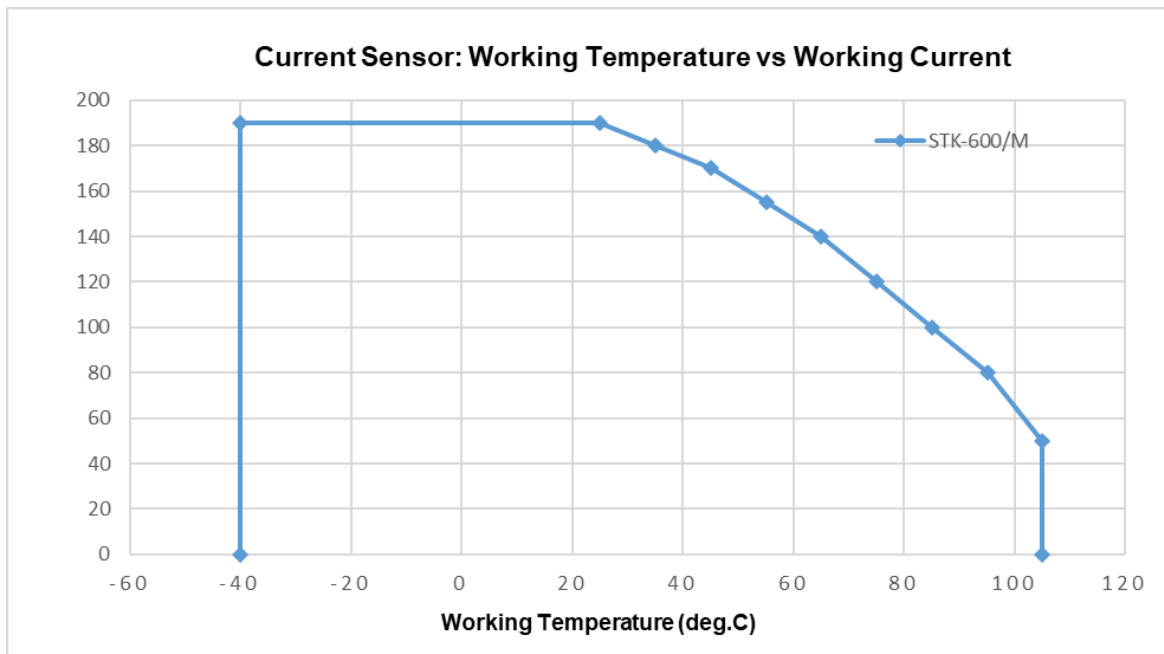

The relationship between working temperature & working current. It is suggested that the temperature of sensor not exceed 105 deg.C for better accuracy.

5. Electrical Data

 Condition: $T_A = 25^{\circ}\text{C}$, STK-600/M-XXXAB5

Parameter	Symbol	Unit	Min	Typ	Max	Comment
Primary nominal current	I_{PN}	A		50		STK-600/M-050AB5
				100		others
Current range (refer remark)	I_{PM}	A	-50		50	STK-600/M-050AB5
			-100		100	STK-600/M-100AB5
			-150		150	STK-600/M-150AB5
			-166		166	STK-600/M-166AB5
			-200		200	STK-600/M-200AB5
			-250		250	STK-600/M-250AB5
			-300		300	STK-600/M-300AB5
			-400		400	STK-600/M-400AB5
Sensitivity	Sens	mV/A		40		STK-600/M-050AB5
				20		STK-600/M-100AB5
				13.33		STK-600/M-150AB5
				12		STK-600/M-166AB5
				10		STK-600/M-200AB5
				8		STK-600/M-250AB5
				6.66		STK-600/M-300AB5
				5		STK-600/M-400AB5
Supply voltage	V_{CC}	V		$5 \pm 5\%$		All
Current consumption	I_{CC}	mA		6		All
Quiescent voltage $V_{out} @ 0\text{ A}$	V_{off}	V	2.48	2.5	2.52	STK-600/M-XXXAB5
Peak output voltage ($V_{out} @ \pm I_{PM}$) - V_{off}	V_{FS}	V		± 2		STK-600/M-XXXAB5
Internal output resistance	R_{out}	Ω		2		All
Rated linearity error	E_{LIN}	% I_{PN}		± 1		$\pm I_{PN}$
Step response time @90% of I_{PM}	t_{res}	μs		4.6		STK-600/M-XXXAB5
Frequency bandwidth (-3dB)	BW	kHz		120		STK-600/M-XXXAB5
Output voltage noise DC ~ 10 kHz DC ~ 100 kHz	V_{noise}	mVpp		20		All
				30		
Accuracy @ 25°C	E_{TOT}	% of I_{PM}	-2.4	± 1	2.4	All
Accuracy @ $-40^{\circ}\text{C} \sim 105^{\circ}\text{C}$	E_{TOT}	% of I_{PM}	-3.5		3.5	All

Condition: $T_A = 25^{\circ}\text{C}$, STK-600/M-XXXAB3

Parameter	Symbol	Unit	Min	Typ	Max	Comment
Primary nominal current	I_{PN}	A		50		STK-600/M-050AB3
				100		others
Current range (refer remark)	I_{PM}	A	-50		50	STK-600/M-050AB3
			-100		100	STK-600/M-100AB3
			-150		150	STK-600/M-150AB3
			-200		200	STK-600/M-200AB3
			-250		250	STK-600/M-250AB3
			-300		300	STK-600/M-300AB3
			-400		400	STK-600/M-400AB3
Sensitivity	Sens	mV/A		26.4		STK-600/M-050AB3
				13.2		STK-600/M-100AB3
				8.8		STK-600/M-150AB3
				6.6		STK-600/M-200AB3
				5.28		STK-600/M-250AB3
				4.4		STK-600/M-300AB3
				3.3		STK-600/M-400AB3
Supply voltage	V_{CC}	V		$3.3 \pm 5\%$		All
Current consumption	I_{CC}	mA		6		All
Quiescent voltage $V_{out} @ 0\text{ A}$	V_{off}	V	1.63	1.65	1.67	STK-600/M-XXXAB3
Peak output voltage ($V_{out} @ \pm I_{PM}$) - V_{off}	V_{FS}	V		± 1.32		STK-600/M-XXXAB3
Internal output resistance	R_{out}	Ω		2		All
Rated linearity error	E_{LIN}	% I_{PN}		± 1		$\pm I_{PN}$
Step response time @90% of I_{PM}	t_{res}	μs		4.6		STK-600/M-XXXAB3
Frequency bandwidth (-3dB)	BW	kHz		120		STK-600/M-XXXAB3
Output voltage noise DC ~ 10 kHz DC ~ 100 kHz	V_{noise}	mVpp		20 30		All
Accuracy @ 25°C	E_{TOT}	% of I_{PM}	-2.4	± 1	2.4	All
Accuracy @ $-40^{\circ}\text{C} \sim 105^{\circ}\text{C}$	E_{TOT}	% of I_{PM}	-3.5		3.5	All

Condition: $T_A = 25^{\circ}\text{C}$, STK-600/M-XXXAC3

Parameter	Symbol	Unit	Min	Typ	Max	Comment
Primary nominal current	I_{PN}	A		100		All
Current range (refer remark)	I_{PM}	A	-200		200	STK-600/M-200AC3
			-250		250	STK-600/M-250AC3
Sensitivity	Sens	mV/A		6		STK-600/M-200AC3
				4.8		STK-600/M-250AC3
Supply voltage	V_{CC}	V		$3.3 \pm 5\%$		All
Current consumption	I_{CC}	mA		6		All
Quiescent voltage $V_{out} @ 0\text{ A}$	V_{off}	V	1.48	1.5	1.52	STK-600/M-XXXAC3
Peak output voltage ($V_{out} @ \pm I_{PM}$) - V_{off}	V_{FS}	V		± 1.2		STK-600/M-XXXAC3
Internal output resistance	R_{out}	Ω		2		All
Rated linearity error	E_{LIN}	% I_{PN}		± 1		$\pm I_{PN}$
Step response time @90% of I_{PM}	t_{res}	μs		4.6		STK-600/M-XXXAC3
Frequency bandwidth (-3dB)	BW	kHz		120		STK-600/M-XXXAC3
Output voltage noise DC ~ 10 kHz DC ~ 100 kHz	V_{noise}	mVpp		20 30		All
Accuracy @ 25°C	E_{TOT}	% of I_{PM}	-2.4	± 1	2.4	All
Accuracy @ $-40^{\circ}\text{C} \sim 105^{\circ}\text{C}$	E_{TOT}	% of I_{PM}	-3.5		3.5	All

Condition: $T_A = 25^{\circ}\text{C}$, STK-600/M-XXXAU5

Parameter	Symbol	Unit	Min	Typ	Max	Comment
Primary nominal current	I_{PN}	A		50		STK-600/M-050AU5
				100		others
Current range (refer remark)	I_{PM}	A	0		50	STK-600/M-050AU5
			0		100	STK-600/M-100AU5
			0		150	STK-600/M-150AU5
			0		200	STK-600/M-200AU5
			0		250	STK-600/M-250AU5
			0		300	STK-600/M-300AU5
			0		400	STK-600/M-400AU5
Sensitivity	Sens	mV/A		80		STK-600/M-050AU5
				40		STK-600/M-100AU5
				26.67		STK-600/M-150AU5
				20		STK-600/M-200AU5
				16		STK-600/M-250AU5
				13.33		STK-600/M-300AU5
				10		STK-600/M-400AU5
Supply voltage	V_{CC}	V		$5 \pm 5\%$		All
Current consumption	I_{CC}	mA		6		All
Quiescent voltage $V_{out} @ 0\text{ A}$	V_{off}	V	0.48	0.5	0.52	STK-600/M-XXXAU5
Peak output voltage ($V_{out} @ \pm I_{PM}$) - V_{off}	V_{FS}	V		4		STK-600/M-XXXAU5
Internal output resistance	R_{out}	Ω		2		All
Rated linearity error	E_{LIN}	% I_{PN}		± 1		$\pm I_{PN}$
Step response time @90% of I_{PM}	t_{res}	μs		4.6		STK-600/M-XXXAU5
Frequency bandwidth (-3dB)	BW	kHz		120		STK-600/M-XXXAU5
Output voltage noise DC ~ 10 kHz DC ~ 100 kHz	V_{noise}	mVpp		20 30		All
Accuracy @ 25°C	E_{TOT}	% of I_{PM}	-2.4	± 1	2.4	All
Accuracy @ $-40^{\circ}\text{C} \sim 105^{\circ}\text{C}$	E_{TOT}	% of I_{PM}	-3.5		3.5	All

Condition: $T_A = 25^{\circ}\text{C}$, STK-600/M-XXXAU3

Parameter	Symbol	Unit	Min	Typ	Max	Comment
Primary nominal current	I_{PN}	A		100		All
Current range (refer remark)	I_{PM}	A	0		100	STK-600/M-100AU3
			0		150	STK-600/M-150AU3
Sensitivity	Sens	mV/A		26.4		STK-600/M-100AU3
				17.6		STK-600/M-150AU3
Supply voltage	V_{CC}	V		$3.3 \pm 5\%$		All
Current consumption	I_{CC}	mA		6		All
Quiescent voltage $V_{out} @ 0\text{ A}$	V_{off}	V	0.31	0.33	0.35	STK-600/M-XXXAU3
Peak output voltage ($V_{out} @ \pm I_{PM}$) - V_{off}	V_{FS}	V		2.64		STK-600/M-XXXAU3
Internal output resistance	R_{out}	Ω		2		All
Rated linearity error	E_{LIN}	% I_{PN}		± 1		$\pm I_{PN}$
Step response time @90% of I_{PM}	t_{res}	μs		4.6		STK-600/M-XXXAU3
Frequency bandwidth (-3dB)	BW	kHz		120		STK-600/M-XXXAU3
Output voltage noise DC ~ 10 kHz DC ~ 100 kHz	V_{noise}	mVpp		20		All
				30		
Accuracy @ 25°C	E_{TOT}	% of I_{PM}	-2.4	± 1	2.4	All
Accuracy @ $-40^{\circ}\text{C} \sim 105^{\circ}\text{C}$	E_{TOT}	% of I_{PM}	-3.5		3.5	All

6. Response Time

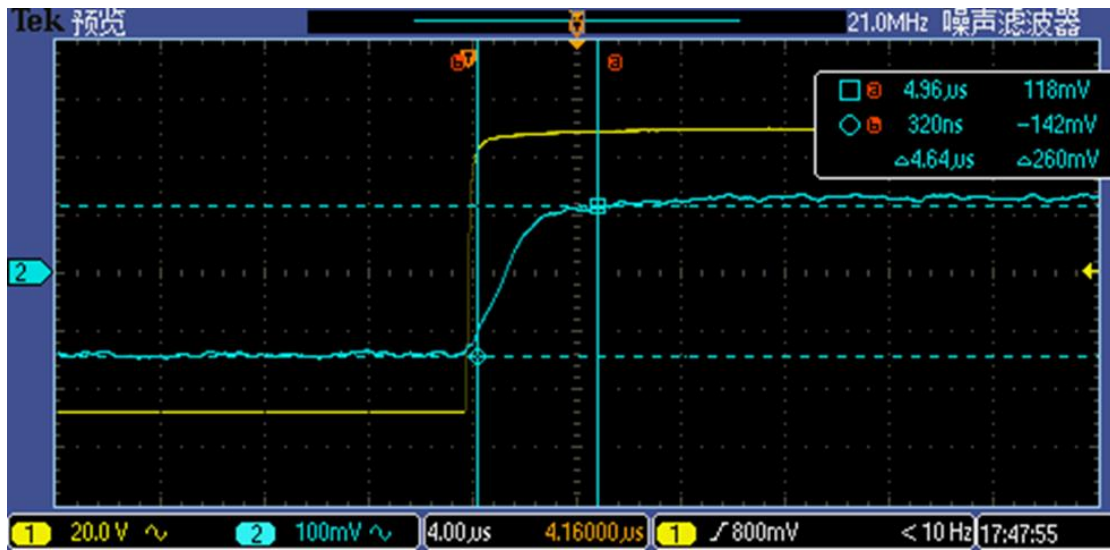

STK-600/M response time

7. Frequency Bandwidth

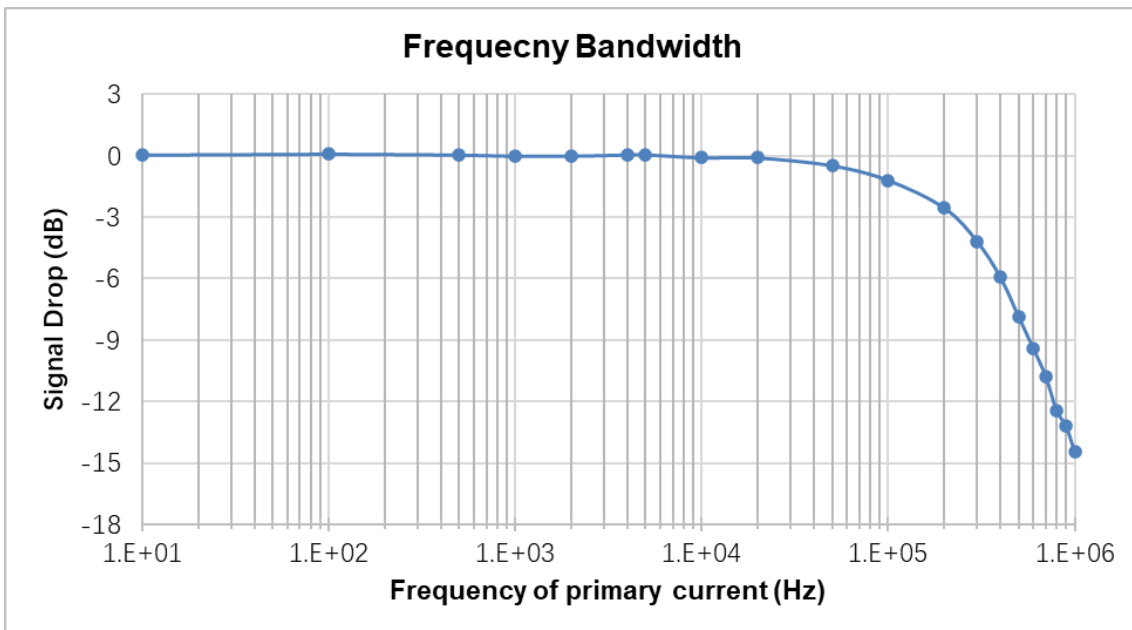

STK-600/M bandwidth

8. Dimension & Pin Definitions

Package, Leadform PFF

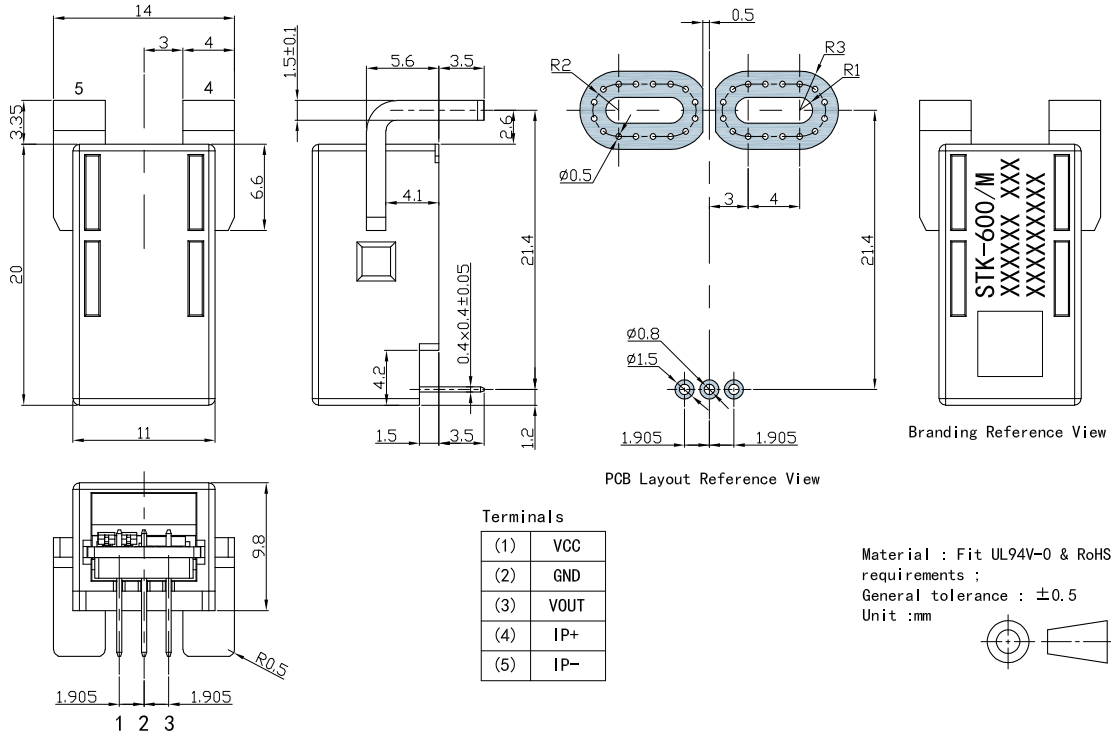

Package, Leadform PSF

