

CURRENT SENSOR

PRODUCT SERIES: STB-CAS

STB-15CAS

STB-25CAS

STB-50CAS

STB-15CAS/R

STB-25CAS/R

PRODUCT PART NUMBER: STB-50CAS/R

STB-15CAS/K

STB-25CAS/K

STB-50CAS/K

STB-75CAS/K

REVISION: Ver 4.8

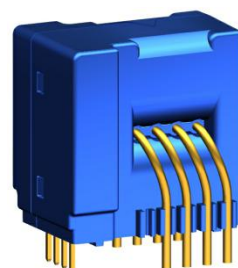
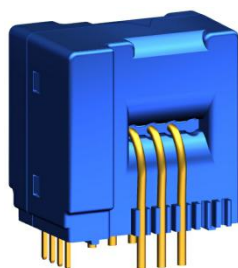
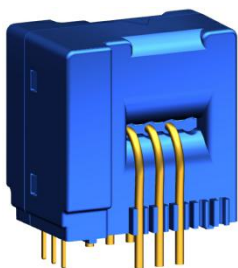

Sinomags Technology Co., Ltd.

CONTENT

1.	Description.....	2
2.	STB-15CAS parameters.....	3
3.	STB-25CAS parameters.....	4
4.	STB-50CAS parameters.....	5
5.	STB-15CAS/R parameters.....	6
6.	STB-25CAS/R parameters.....	7
7.	STB-50CAS/R parameters.....	8
8.	STB-15CAS/K parameters.....	9
9.	STB-25CAS/K parameters.....	10
10.	STB-50CAS/K parameters.....	11
11.	STB-75CAS/K parameters.....	12
12.	Frequency band width.....	13
13.	Step response time.....	13
14.	Frequency delay performace.....	14
15.	Typical application circuits.....	15
16.	Dimensions: STB-CAS.....	17
17.	Dimensions: STB-CAS/R.....	18
18.	Dimensions: STB-CAS/K.....	19

1. Description

STB-CAS series current sensors are based on close loop principle with TMR technology. The sensor can detect the current with DC, AC, pulse and irregular wave shape.

Typical application

- Variable frequency converter
- Uninterruptible Power Supplies (UPS)
- Solar inverters.
- Direct-current dynamo
- Switched model power supplies (SMPS)

General parameters

Parameter	Symbol	Unit	Value
Working temperature	T_A	°C	-40 ~ 105
Storage temperature	T_stg	°C	-40 ~ 105
Mass	m	g	13

Absolute parameters

Parameters	Symbol	Unit	Value
Supply voltage	Vc	V	6
ESD rating (HBM)	U_ESD	kV	4

Remark: the unrecoverable damage may occur when the product works on the conditions over the absolute maximum ratings. Long-time working on the absolute maximum ratings may cause the degradation on performance and reliability.

Isolation parameters

Parameter	Symbol	Unit	Value	Remark
RMS voltage for AC test 50Hz/1 min	Ud	kV	4	
Impulse withstand voltage 1.2/50μs	Ūw	kV	6	
Clearance distance (pri.-sec)	dCl	mm	9.5	Shortest distance through air
Creepage distance (pri.-sec)	dCp	mm	9.5	Shortest path along device body
Electrical clearance	dCe	mm	6.1 (CAS/R)	When mounted on PCB with recommended layout
			6.3 (CAS)	
			8.5 (CAS/K)	
Case material			V0 according to UL 94	
Comparative tracking index	CTI	V	600	

2. STB-15CAS parameters

Condition: $V_{cc} = 5.0\text{ V}$, $NP = 1$, $RL = 10\text{ K}\Omega$, $T_A = 25^\circ\text{C}$, unless specified.

Parameters	Symbol	Unit	Min.	Typ.	Max.	Remark
Primary nominal rms current	I_{pn}	A		15		
Primary current measuring range	I_{pm}	A	-51		51	
Supply voltage	V_c	V	4.75	5	5.25	
Consumption current	I_c	mA		$15 + IP*NP/NS*1000$		NS =1200
Current turns	NP	Turn		1, 2, 3		
Offset voltage	V_{off}	V	2.48	2.5	2.52	Output @ 0 A
Output voltage @ I_{pn}	V_{FS}	V		$V_{off} \pm 0.625$		
Output voltage @ I_{pm}	V_{FSM}	V		$V_{off} \pm 1.875$		
Theoretical sensitivity	G_{th}	mV/A		41.67		0.625V @ I_{pn}
Linearity error 0 ~ I_{pn}	ξ_L	% of I_{pn}		0.3		Tested @25°C
Reaction time @ 10 % of I_{PN}	t_{ra}	μs		0.3		
Step response time @ 90 % of I_{pn}	t_r	μs		0.3		
-3 dB band width	BW	kHz		400		
Noise DC ~ 10 kHz DC ~ 100 kHz	V_{noise}	mVpp		5 6		
Accuracy @ RT	X	% of I_{pn}	-0.8		0.8	@ 25°C
Accuracy @ $T_A = 85^\circ\text{C}$ (105 °C)	X_{TRange}	% of I_{pn}	-2.5 (-3)		2.5 (3)	-40°C ~ 105°C

3. STB-25CAS parameters

Condition: $V_{cc} = 5.0\text{ V}$, $NP = 1$, $R_L = 10\text{ K}\Omega$, $T_A = 25^\circ\text{C}$, unless specified.

Parameters	Symbol	Unit	Min.	Typ.	Max.	Remark
Primary nominal rms current	I_{pn}	A		25		
Primary current measuring range	I_{pm}	A	-85		85	
Supply voltage	V_c	V	4.75	5	5.25	
Consumption current	I_c	mA		$15 + IP*NP/NS*1000$		NS =1200
Current turns	NP	Turn		1, 2, 3		
Offset voltage	V_{off}	V	2.48	2.5	2.52	Output @ 0 A
Output voltage @ I_{pn}	V_{FS}	V		$V_{off} \pm 0.625$		
Output voltage @ I_{pm}	V_{FSM}	V		$V_{off} \pm 1.875$		
Theoretical sensitivity	G_{th}	mV/A		25		0.625V @ I_{pn}
Linearity error 0 ~ I_{pn}	ξ_L	% of I_{pn}		0.3		Tested @25°C
Reaction time @ 10 % of I_{PN}	t_{ra}	μs		0.3		
Step response time @ 90 % of I_{pn}	t_r	μs		0.3		
-3 dB band width	BW	kHz		400		
Noise DC ~ 10 kHz DC ~ 100 kHz	V_{noise}	mVpp		5 6		
Accuracy @ RT	X	% of I_{pn}	-0.8		0.8	@ 25°C
Accuracy @ $T_A = 85^\circ\text{C}$ (105 °C)	X_{TRange}	% of I_{pn}	-2.5 (-3)		2.5 (3)	-40°C ~ 105°C

4. STB-50CAS parameters

Condition: $V_{CC} = 5.0\text{ V}$, $N_P = 1$, $R_L = 10\text{ k}\Omega$, $T_A = 25^\circ\text{C}$, unless specified.

Parameters	Symbol	Unit	Min.	Typ.	Max.	Remark
Primary nominal rms current	I_{pn}	A		50		
Primary current measuring range	I_{pm}	A	-150		150	
Supply voltage	V_c	V	4.75	5	5.25	
Consumption current	I_c	mA		$15 + IP*NP/NS*1000$		NS =1200
Current turns	NP	Turn		1, 2, 3		
Offset voltage	V_{off}	V	2.48	2.5	2.52	
Output voltage @ I_{pn}	V_{FS}	V		$V_{off} \pm 0.625$		
Output voltage @ I_{pm}	V_{FSM}	V		$V_{off} \pm 1.875$		
Theoretical sensitivity	G_{th}	mV/A		12.5		0.625V @ I_{pn}
Linearity error 0 ~ I_{pn}	ξ_L	% of I_{pn}		0.3		Tested @25°C
Reaction time @ 10 % of I_{PN}	t_{ra}	μs		0.3		
Step response time @ 90 % of I_{pn}	t_r	μs		0.3		
-3 dB band width	BW	kHz		400		
Noise DC ~ 10 kHz DC ~ 100 kHz	V_{noise}	mVpp		5 6		
Accuracy @ RT	X	% of I_{pn}	-0.8		0.8	@ 25°C
Accuracy @ $T_A = 85^\circ\text{C}$ (105 °C)	X_{TRange}	% of I_{pn}	-2.5(-3)		2.5 (3)	-40°C ~ 105°C

5. STB-15CAS/R parameters

Condition: $V_{CC} = 5.0\text{ V}$, $N_P = 1$, $R_L = 10\text{ k}\Omega$, $T_A = 25^\circ\text{C}$, unless specified.

Parameters	Symbol	Unit	Min.	Typ.	Max.	Remark
Primary nominal rms current	I_{pn}	A		15		
Primary current measuring range	I_{pm}	A	-51		51	
Supply voltage	V_c	V	4.75	5	5.25	
Consumption current	I_c	mA		$15 + IP*NP/NS*1000$		NS =1200
Current turns	NP	Turn		1、2、3		
Reference voltage	V_{ref}	V	2.48	2.5	2.52	
Output voltage @ I_{pn}	V_{FS}	V		$V_{ref} \pm 0.625$		
Output voltage @ I_{pm}	V_{FSM}	V		$V_{ref} \pm 1.875$		
Electrical offset voltage	V_{OE}	mV		5		100 % tested $V_{out} - V_{ref}@ 0\text{ A}$
Theoretical sensitivity	G_{th}	mV/A		41.667		0.625 V @ I_{pn}
Linearity error 0 ~ I_{pn}	ξ_L	% of I_{pn}		0.3		Tested @25°C
Reaction time @ 10 % of I_{PN}	t_{ra}	μs		0.3		
Step response time @ 90 % of I_{pn}	t_r	μs		0.3		
-3 dB band width	BW	kHz		400		
Noise DC ~ 10 kHz DC ~ 100 kHz	V_{noise}	mVpp		5 6		
Accuracy @ RT	X	% of I_{pn}	-0.8		0.8	@ 25°C
Accuracy @ $T_A = 85^\circ\text{C}$ (105 °C)	X_{TRange}	% of I_{pn}	-1.15 (-1.5)		1.15 (1.5)	-40°C ~ 105°C

6. STB-25CAS/R parameters

Condition: $V_{CC} = 5.0\text{ V}$, $N_P = 1$, $R_L = 10\text{ k}\Omega$, $T_A = 25^\circ\text{C}$, unless specified.

Parameters	Symbol	Unit	Min.	Typ.	Max.	Remark
Primary nominal rms current	I_{pn}	A		25		
Primary current measuring range	I_{pm}	A	-85		85	
Supply voltage	V_c	V	4.75	5	5.25	
Consumption current	I_c	mA		15 + $I_P \cdot N_P / N_S \cdot 1000$		NS =1200
Current turns	N_P	Turn		1、2、3		
Reference voltage	V_{ref}	V	2.48	2.5	2.52	
Output voltage @ I_{pn}	V_{FS}	V		$V_{ref} \pm 0.625$		
Output voltage @ I_{pm}	V_{FSM}	V		$V_{ref} \pm 1.875$		
Electrical offset voltage	V_{OE}	mV		5		100 % tested $V_{out} - V_{ref}@$ 0 A
Theoretical sensitivity	G_{th}	mV/A		25		0.625 V @ I_{pn}
Linearity error 0 ~ I_{pn}	ξ_L	% of I_{pn}		0.3		Tested @25°C
Reaction time @ 10 % of I_{PN}	t_{ra}	μs		0.3		
Step response time @ 90 % of I_{pn}	t_r	μs		0.3		
-3 dB band width	BW	kHz		400		
Noise DC ~ 10 kHz DC ~ 100 kHz	V_{noise}	mVpp		5 6		
Accuracy @ RT	X	% of I_{pn}	-0.8		0.8	@ 25°C
Accuracy @ T_A = 85 °C (105 °C)	X_{TRange}	% of I_{pn}	-1.15 (-1.3)		1.15 (1.3)	-40°C ~ 105°C

7. STB-50CAS/R parameters

Condition: $V_{cc} = 5.0\text{ V}$, $NP = 1$, $R_L = 10\text{ k}\Omega$, $T_A = 25^\circ\text{C}$, unless specified.

Parameters	Symbol	Unit	Min.	Typ.	Max.	Remark
Primary nominal rms current	I_{pn}	A		50		
Primary current measuring range	I_{pm}	A	-150		150	
Supply voltage	V_c	V	4.75	5	5.25	
Consumption current	I_c	mA		$15 + IP*NP/NS*1000$		NS =1200
Current turns	NP	Turn		1、2、3		
Reference voltage	V_{ref}	V	2.48	2.5	2.52	
Output voltage @ I_{pn}	V_{FS}	V		$V_{ref} \pm 0.625$		
Output voltage @ I_{pm}	V_{FSM}	V		$V_{ref} \pm 1.875$		
Electrical offset voltage	V_{OE}	mV		5		100 % tested $V_{out} - V_{ref}@ 0\text{ A}$
Theoretical sensitivity	G_{th}	mV/A		12.5		0.625 V @ I_{pn}
Linearity error 0 ~ I_{pn}	ξ_L	% of I_{pn}		0.3		Tested @25°C
Reaction time @ 10 % of I_{PN}	t_{ra}	μs		0.3		
Step response time @ 90 % of I_{pn}	t_r	μs		0.3		
-3 dB band width	BW	kHz		400		
Noise DC ~ 10 kHz DC ~ 100 kHz	V_{noise}	mVpp		5 6		
Accuracy @ RT	X	% of I_{pn}	-0.8		0.8	@ 25°C
Accuracy @ $T_A = 85^\circ\text{C}$ (105 °C)	X_{TRange}	% of I_{pn}	-1.1 (-1.3)		1.1 (1.3)	-40°C ~ 105°C

8. STB-15CAS/K parameters

Condition: $V_{CC} = 5.0\text{ V}$, $N_P = 1$, $R_L = 10\text{ k}\Omega$, $T_A = 25^\circ\text{C}$, unless specified.

Parameters	Symbol	Unit	Min.	Typ.	Max.	Remark
Primary nominal rms current	I_{pn}	A		15		
Primary current measuring range	I_{pm}	A	-51		51	
Supply voltage	V_c	V	4.75	5	5.25	
Consumption current	I_c	mA		15 + $I_P \cdot N_P / N_S \cdot 1000$		NS =1200
Current turns	N_P	Turn		1, 2, 4		
Reference voltage	V_{ref}	V	2.48	2.5	2.52	
Output voltage @ I_{pn}	V_{FS}	V		$V_{ref} \pm 0.625$		
Output voltage @ I_{pm}	V_{FSM}	V		$V_{ref} \pm 1.875$		
Electrical offset voltage	V_{OE}	mV		5		100 % tested $V_{out} - V_{ref} @ 0\text{ A}$
Theoretical sensitivity	G_{th}	mV/A		41.67		0.625 V @ I_{pn}
Linearity error 0 ~ I_{pn}	ξ_L	% of I_{pn}		0.3		Tested @25°C
Reaction time @ 10 % of I_{PN}	t_{ra}	μs		0.3		
Step response time @ 90 % of I_{pn}	t_r	μs		0.3		
-3 dB band width	BW	kHz		400		
Noise DC ~ 10 kHz DC ~ 100 kHz	V_{noise}	mVpp		5 6		
Accuracy @ RT	X	% of I_{pn}	-0.8		0.8	@ 25°C
Accuracy @ $T_A = 85^\circ\text{C}$ (105 °C)	X_{TRange}	% of I_{pn}	-1.15 (-1.3)		1.15 (1.3)	-40°C ~ 105°C

9. STB-25CAS/K parameters

Condition: $V_{CC} = 5.0\text{ V}$, $N_P = 1$, $R_L = 10\text{ k}\Omega$, $T_A = 25^\circ\text{C}$, unless specified.

Parameters	Symbol	Unit	Min.	Typ.	Max.	Remark
Primary nominal rms current	I_{pn}	A		25		
Primary current measuring range	I_{pm}	A	-85		85	
Supply voltage	V_c	V	4.75	5	5.25	
Consumption current	I_c	mA		$15 + IP*NP/NS*1000$		NS =1200
Current turns	NP	Turn		1, 2, 4		
Reference voltage	V_{ref}	V	2.48	2.5	2.52	
Output voltage @ I_{pn}	V_{FS}	V		$V_{ref} \pm 0.625$		
Output voltage @ I_{pm}	V_{FSM}	V		$V_{ref} \pm 1.875$		
Electrical offset voltage	V_{OE}	mV		5		100 % tested $V_{out} - V_{ref}@ 0\text{ A}$
Theoretical sensitivity	G_{th}	mV/A		25		0.625 V @ I_{pn}
Linearity error 0 ~ I_{pn}	ξ_L	% of I_{pn}		0.3		Tested @25°C
Reaction time @ 10 % of I_{PN}	t_{ra}	μs		0.3		
Step response time @ 90 % of I_{pn}	t_r	μs		0.3		
-3 dB band width	BW	kHz		400		
Noise DC ~ 10 kHz DC ~ 100 kHz	V_{noise}	mVpp		5 6		
Accuracy @ RT	X	% of I_{pn}	-0.8		0.8	@ 25°C
Accuracy @ $T_A = 85^\circ\text{C}$ (105 °C)	X_{TRange}	% of I_{pn}	-1.15 (-1.3)		1.15 (1.3)	-40°C ~ 105°C

10. STB-50CAS/K parameters

Condition: $V_{cc} = 5.0\text{ V}$, $NP = 1$, $R_L = 10\text{ k}\Omega$, $T_A = 25^\circ\text{C}$, unless specified.

Parameters	Symbol	Unit	Min.	Typ.	Max.	Remark
Primary nominal rms current	I_{pn}	A		50		
Primary current measuring range	I_{pm}	A	-150		150	
Supply voltage	V_c	V	4.75	5	5.25	
Consumption current	I_c	mA		$15 + IP*NP/NS*1000$		NS =1200
Current turns	NP	Turn		1, 2, 4		
Reference voltage	V_{ref}	V	2.48	2.5	2.52	
Output voltage @ I_{pn}	V_{FS}	V		$V_{ref} \pm 0.625$		
Output voltage @ I_{pm}	V_{FSM}	V		$V_{ref} \pm 1.875$		
Electrical offset voltage	V_{OE}	mV		5		100 % tested $V_{out} - V_{ref}@ 0\text{ A}$
Theoretical sensitivity	G_{th}	mV/A		12.5		0.625 V @ I_{pn}
Linearity error 0 ~ I_{pn}	ξ_L	% of I_{pn}		0.3		Tested @25°C
Reaction time @ 10 % of I_{PN}	t_{ra}	μs		0.3		
Step response time @ 90 % of I_{pn}	t_r	μs		0.3		
-3 dB band width	BW	kHz		400		
Noise DC ~ 10 kHz DC ~ 100 kHz	V_{noise}	mVpp		5 6		
Accuracy @ RT	X	% of I_{pn}	-0.8		0.8	@ 25°C
Accuracy @ $T_A = 85^\circ\text{C}$ (105 °C)	X_{TRange}	% of I_{pn}	-1.1 (-1.3)		1.1 (1.3)	-40°C ~ 105°C

11. STB-75CAS/K parameters

Condition: $V_{CC} = 5.0\text{ V}$, $NP = 1$, $R_L = 10\text{ k}\Omega$, $T_A = 25^\circ\text{C}$, unless specified.

Parameters	Symbol	Unit	Min.	Typ.	Max.	Remark
Primary nominal rms current	I_{pn}	A		75		
Primary current measuring range	I_{pm}	A	-220		220	
Supply voltage	V_c	V	4.75	5	5.25	
Consumption current	I_c	mA		$15 + IP*NP/NS*1000$		NS =1200
Current turns	NP	Turn		1, 2, 4		
Reference voltage	V_{ref}	V	2.48	2.5	2.52	
Output voltage @ I_{pn}	V_{FS}	V		$V_{ref} \pm 0.4685$		
Output voltage @ I_{pm}	V_{FSM}	V		$V_{ref} \pm 1.125$		
Electrical offset voltage	V_{OE}	mV		5		100 % tested $V_{out} - V_{ref}@ 0\text{ A}$
Theoretical sensitivity	G_{th}	mV/A		6.25		0.4685 V @ I_{pn}
Linearity error 0 ~ I_{pn}	ξ_L	% of I_{pn}		0.3		Tested @25°C
Reaction time @ 10 % of I_{PN}	t_{ra}	μs		0.3		
Step response time @ 90 % of I_{pn}	t_r	μs		0.3		
-3 dB band width	BW	kHz		400		
Noise DC ~ 10 kHz DC ~ 100 kHz	V_{noise}	mVpp		5 6		
Accuracy @ RT	X	% of I_{pn}	-0.8		0.8	@ 25°C
Accuracy @ $T_A = 85^\circ\text{C}$ (105 °C)	X_{TRange}	% of I_{pn}	-1.1 (-1.3)		1.1 (1.3)	-40°C ~ 105°C

12. Frequency band width

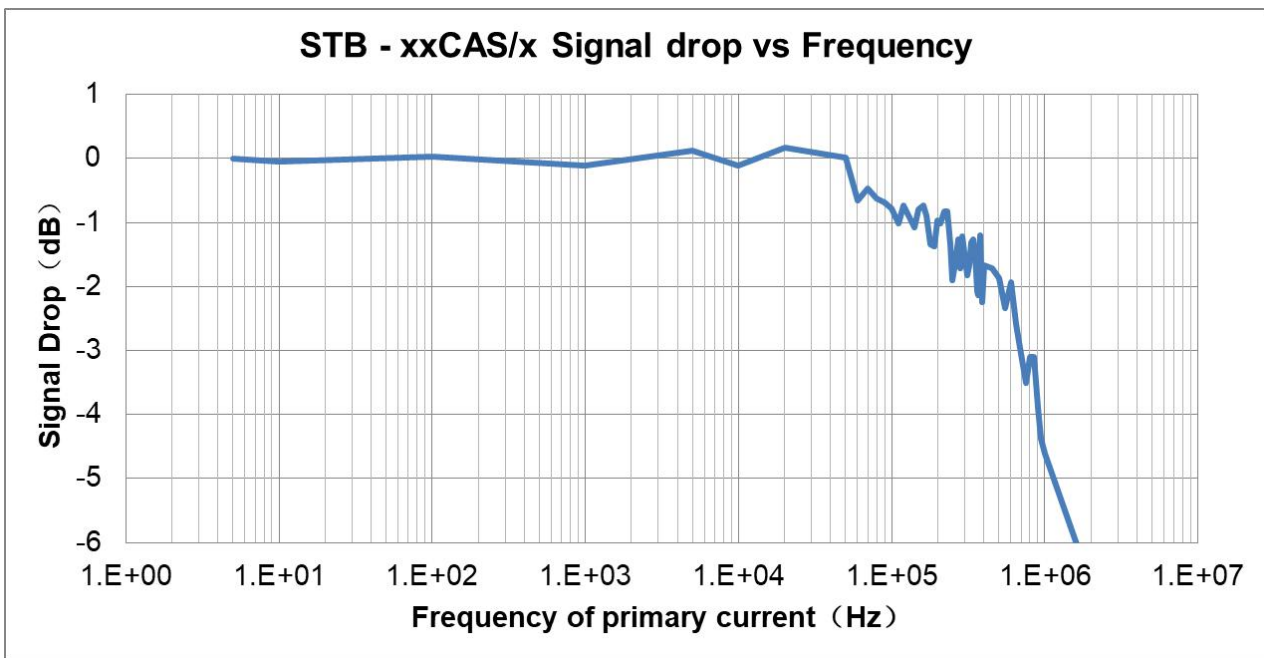

Fig.1 the band width of STB-xxCAS/x series current sensors. The bandwidth was tested after differential amplification with 1x magnification.

13. Step response time

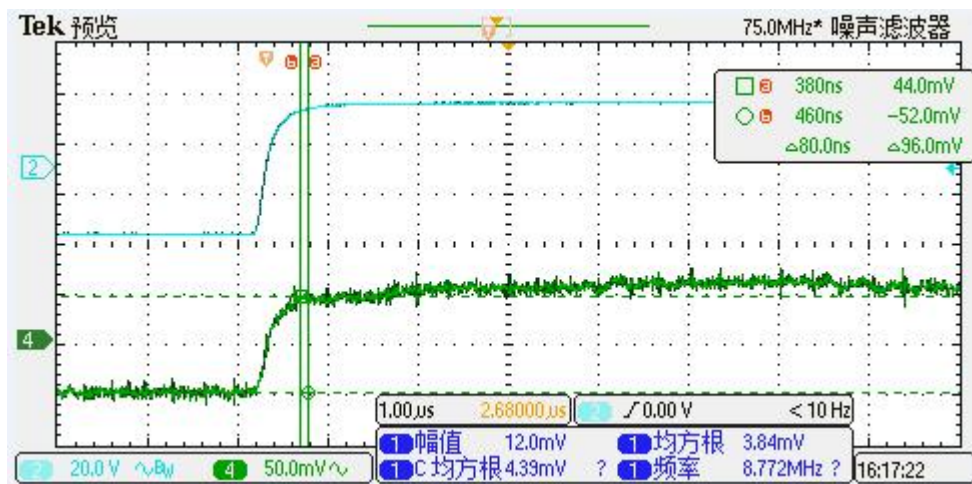

Fig.2 the step response time of STB-xxCAS current sensors. The blue is primary current, while the green is output signal of current sensor. The step response time is less than 0.3 μ s.

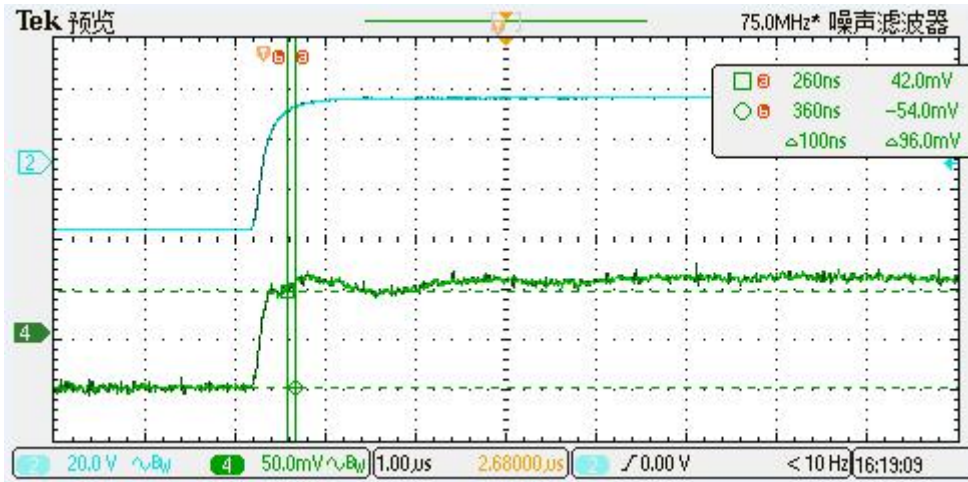

Fig.4 the step response time of STB-xxCAS/R & STB-xxCAS/K current sensors. The blue line is primary current, while the green line is output signal of current sensor. The step response time is less than 0.3 μ s.

14. Frequency delay performance

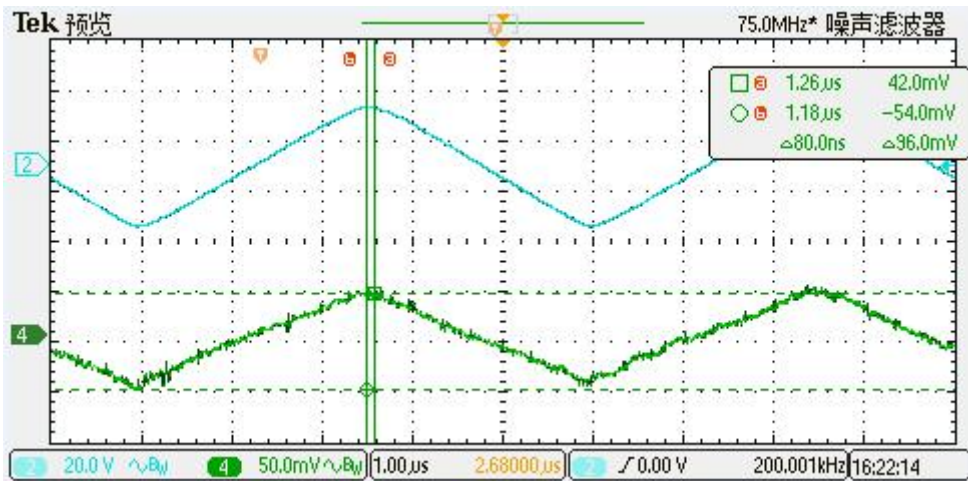
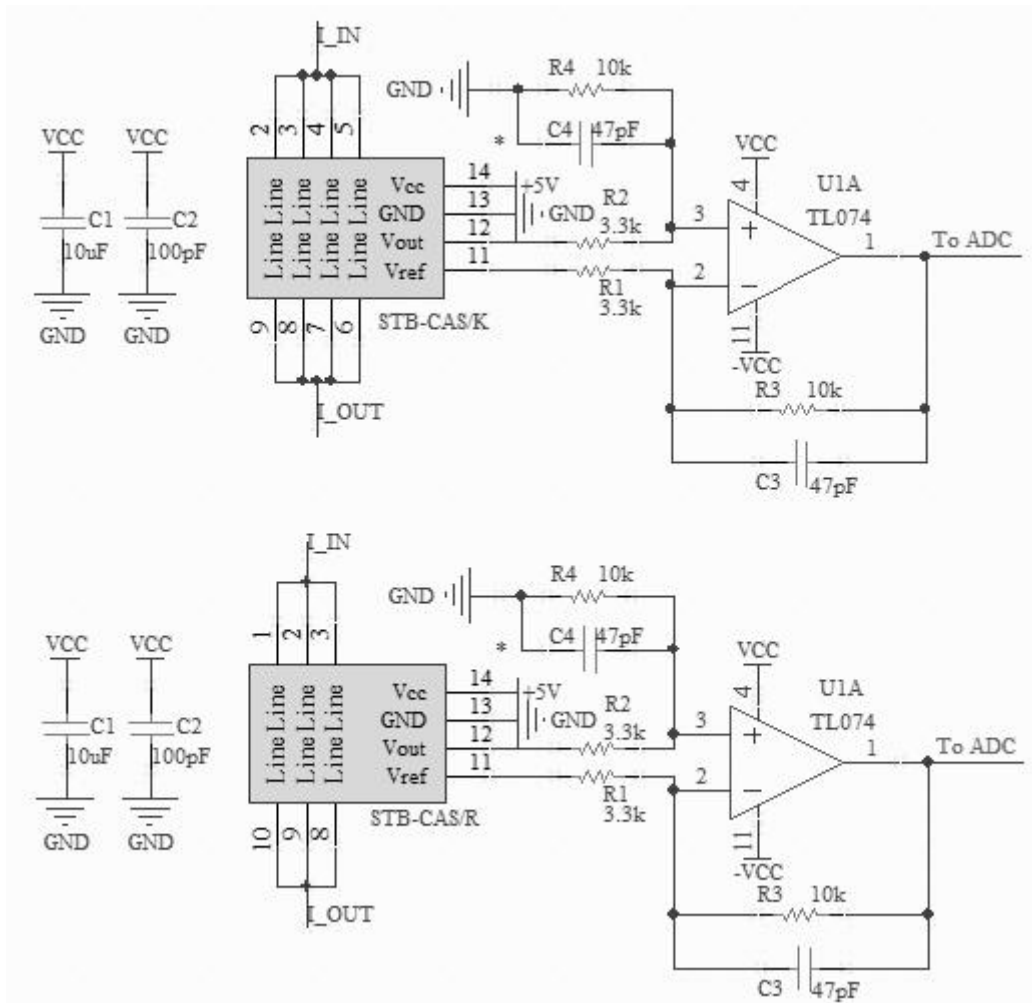
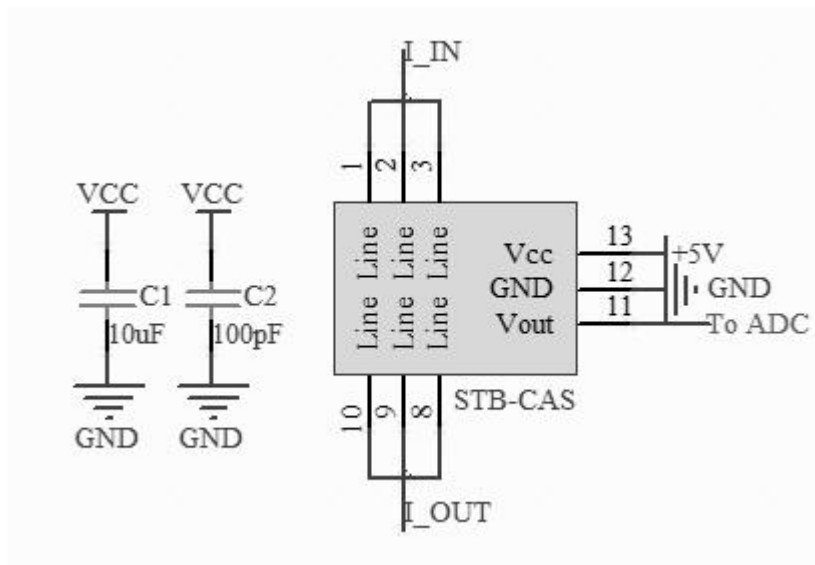

Fig.5 when detection the primary current with a frequency of 200 kHz. The delay time from primary current (blue) to the output of the sensor (green) is less than 0.3 μ s.

15. Typical application circuits



Typical application circuits for STB-CAS/K & STB-CAS/R current sensor. The magnification can be estimated as $M = R4 / R2$ with the condition of $R1 = R2$, and $R3 = R4$. The magnification in the circuit above is around 3.



Typical application circuits for STB-CAS current sensor. The output and reference voltage can directly input to the ADC.

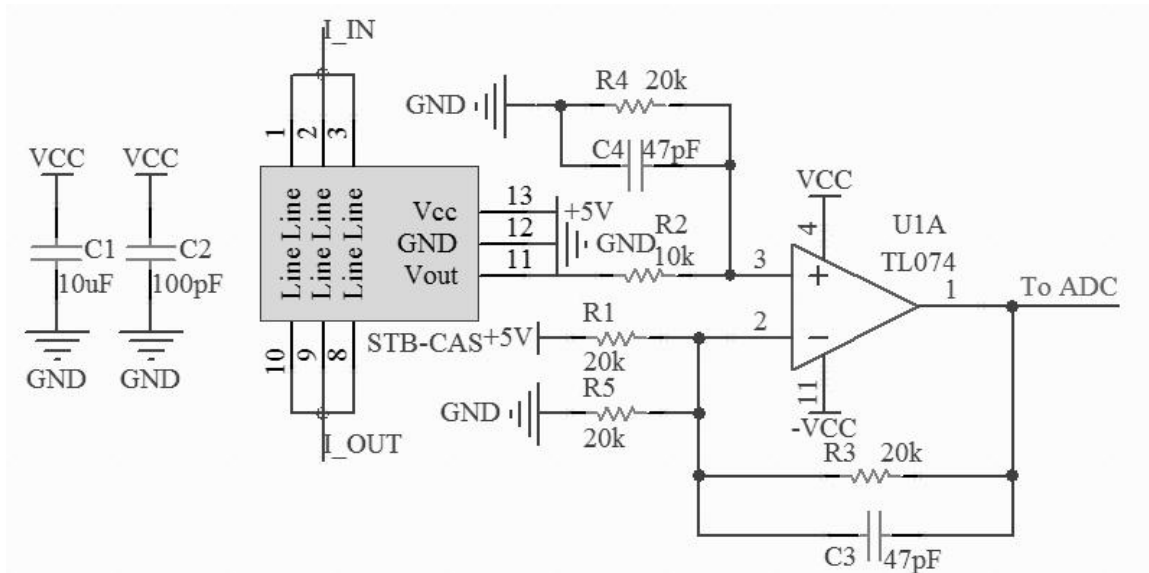

Typical application circuits for CTB-CAS current sensor. The magnification can be estimated as $M = R4 / R2$ with the condition of $R1 // R5 = R2$, $R1 = R5$, and $R3 = R4$. The magnification in the circuit above is around 2.

$R3 \text{ (ohm)} = R4 \text{ (ohm)}$	$C3 \text{ (pF)} = C4 \text{ (pF)}$	Theoretical -3dB $f = 1/(2\pi RC)$ (kHz)	Tested -3dB (kHz)
20000	20	398	~ 400
20000	81	98	~ 100
20000	810	10	~ 10

The frequency characteristics of STB-CAS/X series current sensor are not affected by the R-C setting (according to recommended R-C setting), therefore the active filter circuit or R-C circuit can be applied to modulate the sensor's frequency characteristics.

16. Dimensions: STB-CAS

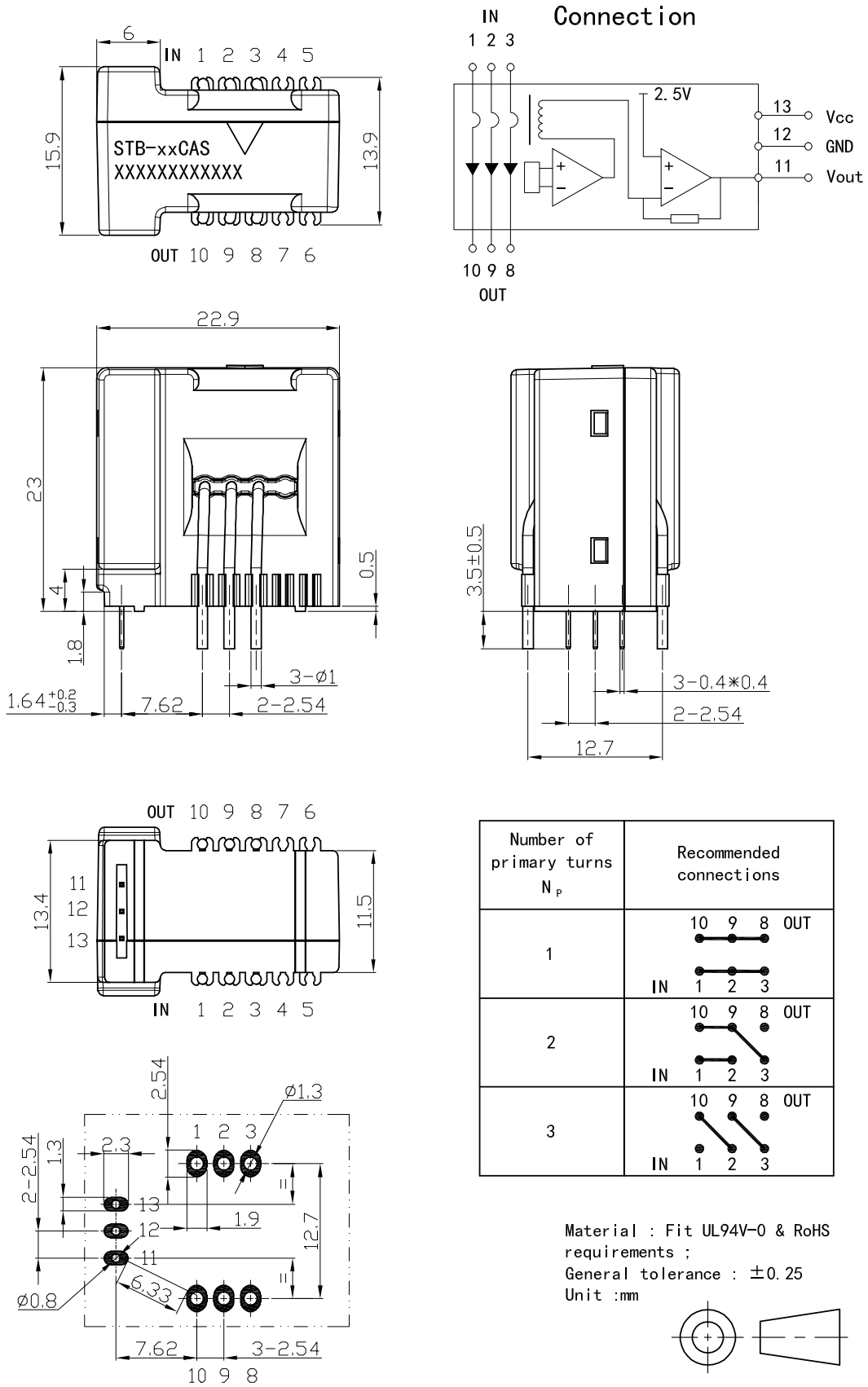

17. Dimensions: STB-CAS/R

